

This article was downloaded by:

On: 22 January 2011

Access details: *Access Details: Free Access*

Publisher *Taylor & Francis*

Informa Ltd Registered in England and Wales Registered Number: 1072954 Registered office: Mortimer House, 37-41 Mortimer Street, London W1T 3JH, UK



The Journal of Adhesion

Publication details, including instructions for authors and subscription information:

<http://www.informaworld.com/smpp/title~content=t713453635>

Contribution of Charge to Powder Particle Adhesion

D. K. Donald^a

^a Xerox Corporation Research Laboratories, Rochester, New York, U.S.A.

To cite this Article Donald, D. K.(1972) 'Contribution of Charge to Powder Particle Adhesion', The Journal of Adhesion, 4: 3, 233 – 245

To link to this Article: DOI: 10.1080/00218467208072226

URL: <http://dx.doi.org/10.1080/00218467208072226>

PLEASE SCROLL DOWN FOR ARTICLE

Full terms and conditions of use: <http://www.informaworld.com/terms-and-conditions-of-access.pdf>

This article may be used for research, teaching and private study purposes. Any substantial or systematic reproduction, re-distribution, re-selling, loan or sub-licensing, systematic supply or distribution in any form to anyone is expressly forbidden.

The publisher does not give any warranty express or implied or make any representation that the contents will be complete or accurate or up to date. The accuracy of any instructions, formulae and drug doses should be independently verified with primary sources. The publisher shall not be liable for any loss, actions, claims, proceedings, demand or costs or damages whatsoever or howsoever caused arising directly or indirectly in connection with or arising out of the use of this material.

Contribution of Charge to Powder Particle Adhesion[†]

D. K. DONALD

*Xerox Corporation Research Laboratories,
Rochester, New York 14603, U.S.A.*

(Received December 6, 1971)

We have measured the charge on gold particles attached to the surfaces of beads and found 22×10^{-15} Coul/particle on these 30 micron particles. In other dusts we had seen charges from $1-70 \times 10^{-15}$ Coul/particle attached to similar surfaces. The attachment forces of 0.1-1 dyne reported for gold particles on metal surfaces could be produced by the particle's charge if a suitably thin ($\sim 100\text{\AA}$) oxide layer insulated the particle's charge from the metal surface. Our gold contained tarnish layers which are both friable and fritable and appear to be suitably thin.

St. John and Montgomery⁵ report the angle of the applied removal force is critical in determining the detachment of particles. We confirm this, but our surface coverage was high enough to allow avalanches to form which complicate the interpretation of the angular phenomena.

INTRODUCTION

There are many common instances where dust particles on a surface are of significant importance. Three examples are window washing¹, furniture cleaning and xerography^{2,3}. In the first two instances we take dust off whereas in the third we put dust on. When cleaning dust off there are two kinds of particles the experimenter must deal with. First, there are the loosely held particles which form most of the dust on the top layer, then secondly, there are the last tenaciously held particles which must be removed from the

[†] This paper was presented at the *Symposium on Recent Advances in Adhesion* during the 162nd National American Chemical Society Meeting, September, 1971.

surface with considerable effort. In most cases physical adhesion experiments reported in the literature^{1,4,5} emphasize the latter particles and have not dealt with the former, loosely held, particles in much detail. The experimenter always finds it easier to examine a substantially clean surface and explore the properties of a sparse sprinkling of particles on the surface rather than explore a comparatively dirty surface where the individuality of particles is lost.

In the past the properties of this more loosely held fraction of particles has always been considered an extension of the properties of thick layers rather than an extension of the properties of very sparsely sprinkled particles. The approach that we examine here is to carry the interpretation and the experiments in a reverse direction. We propose extending our observations on loosely held particles and will attempt to rationalize some properties of tightly held particles as if tightly held particles were a simple extension of the loosely held particle problem.

ANALYSIS

Our thesis is that particles attached to surfaces are electrostatically charged and attached by this charge. We will apply this argument even when both the substrate and the particles are electrical conductors. We assert that this occurs with conductors if a thin oxide or tarnish layer exists on the particle and the thin layer provides a barrier for charge migration. We will also show that it is very difficult to be certain that particles are not charged simply by making electrostatic tests of the properties of surfaces.

We begin the discussion with an ideal spherical particle with unity dielectric constant (ϵ') resting on a substrate. Assume there is a point charge Q residing in a trap on the surface of the particle and that the point charge is h above the substrate as in Figure 1. The point charge could occur, for example, from an earlier triboelectric contact with another object. The force of attraction between the particle and substrate is given in CGS units as:

$$F = \frac{Q^2}{4h^2} \cdot \alpha \quad (1)$$

The image charge in the conductor is h below the surface so the dimensionless parameter α is 1 for our particle. If the particle is polarizable and contains induced charge then the electrical separation between the point charge and its image is reduced and the coefficient α is increased. In addition to attachment there will be a torque on the particle for most orientations of the point charge.

If our particle has had many triboelectric events in its history then there will be a large number of point charges over the surface. If the charge

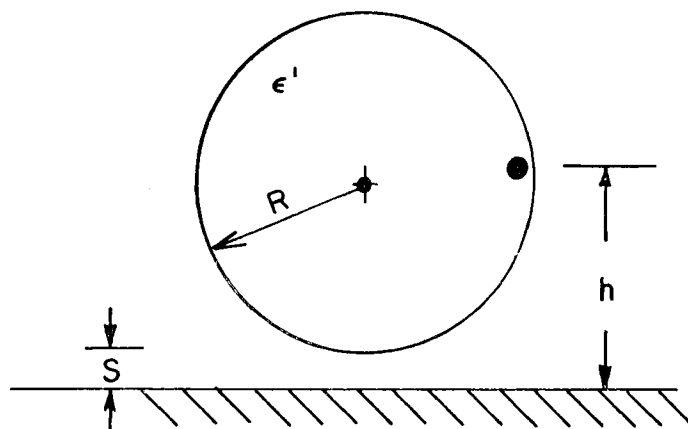

FIGURE 1 A spherical particle of radius R separated by a distance s from a conducting substrate. A point charge Q occurs in a trap at the particle's surface a distance h above the substrate.

distribution is uniform or nearly uniform then a useful formulation for the force is:

$$F = \frac{Q^2}{4R^2} \cdot \alpha \quad (2)$$

Where R is the radius, Q is the total charge and α is the weighted effect from all the point charges of Eq. 1.

On real particles with charge distributed over the surface and with real polarizabilities the contribution of α can be dramatic. Davis has used Maxwell's equations and the method of images to compute the properties for both metal and dielectric particles over conducting substrates elsewhere⁶ and an example of the effect on a metal sphere is important here. A metal particle covered by an oxide layer $S=1/1000$ the particle radius in thickness experiences an electrostatic force 60 times ($\alpha = 60$) the force computed by the first part of Eq. 2. A simple analytic approximation to Davis' result is:

$$\alpha = \left(\frac{R}{3S} \right)^{0.7} \quad (3)$$

for particles closer than $\frac{1}{10}$ radius from the substrate. If the particle were 15 microns in radius, the $S = R/1000$ oxide skin on the particle would be only 150 Å thick and could only be detected by electron microscopy. The parameter α would be the same if an asperity lifted the perfect sphere slightly and the oxide were thinner than 150 Å. With such an oxide the core of the particle is electrically insulated from the substrate.

Suppose the particle is exposed to some external plasma of free ions—a situation which occurs when a radioactive *alpha* source is near the specimen—then we can estimate the time for the particle to lose its charge. If h is large, appreciable electrostatic field exists outside the confines of the particle and therefore external ions will be trapped by the particle and the particle will be discharged. On the other hand, there is almost no external electric field to attract ions if h is small and α is large. The time required for charge to be lost in that case will be far greater than the discharge time for h large.

There is an interesting property of a particle with only a few spots of charge on it. If our particle is oriented at a random angle as is indicated in Figure 1, then there is a torque tending to roll the particle over. If the particle was supplied from an aerosol and the particle floated slowly onto the surface, then this torque would orient the particle for least action and thus an observer would find gently applied particles oriented to maximize α in equation 2.

Finally, an experimenter using an electrostatic probe⁷ to examine the surface potential over the particles we have discussed would be misled about the particle's charge if he used the surface potential and the particle size alone to compute the charge on the particle. The only way that the experimenter can correctly judge the charge on the particles discussed here is to remove the particles from the surface⁸ and measure the charge loss by the surface or the charge carried away on the particles themselves.

One might think that the initial charge on the particle before contact would satisfactorily describe the properties of the particles. However, Derjaguin⁹ and Schnabel¹⁰ pointed out that microscopic electrostatic double layers occur in equilibrium and can grow between two specimens in contact which were not charged to begin with.

PARTICLE SIZE

Assume we have a mass of spherical particles all of equal radii. We would like to know how the adhesion changes as the radius of the particles change. Once this relationship is established, then the experimentalist who is faced with particle size distributions can estimate what to expect in a given experiment.

If the charge on a particle is produced by a multitude of random contacts with the surface it is plausible that the particle may acquire a charge proportional to the surface area of the particle. That is to say the charge is proportional to the radius squared; $Q = \beta R^2$.

If the charge on the particle is determined by one triboelectric event alone the charge may be independent of radius. Between these extremes a host of

radius dependences are possible and these are indicated in Eq. 3 by an arbitrary radius dependence R^n , namely:

$$Q = \beta R^n \quad (4)$$

We can then use the formula and specifically predict the force of attraction of the particle to the substrate and this is written with Eq. 2 to approximate the force,

$$F = \frac{\beta^2 R^{2(n-1)}}{4} \cdot \alpha \quad (5)$$

A different force *vs.* radius relationship occurs if α depends on radius and Eq. 3 is included.

In Figure 2 we plot the radius dependence of the attachment in arbitrary force units assuming particles of 6.5 microns have an attachment force of 0.065 arbitrary units.

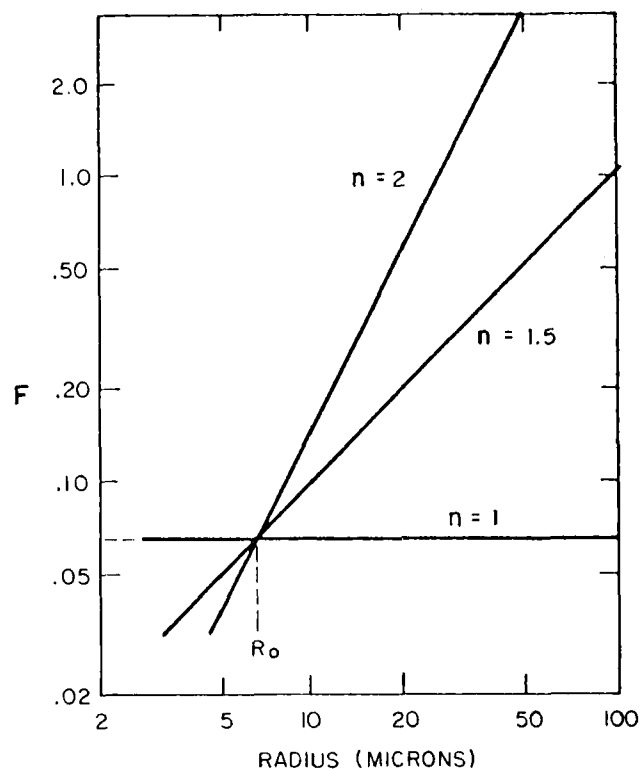

FIGURE 2 Attachment force measured in arbitrary units is compared with particle radius following Eq. 4. For simplicity the forces were normalized at one radius.

APPARATUS

Two kinds of experimental arrangements were used and we believe the arrangements should produce some differences in results. In one case dust was applied to a smooth surface. In the other case an assembly of glass beads was used to hold the dust.

Dust was applied to the assembly of glass beads by shaking the beads and dust together in a beaker. The beads quickly picked up the powder to an equilibrium coverage which usually varied from 1–80%. With certain combinations of materials² the dust was not appreciably picked up by the beads.

A sample consisting of a mixture of dust on beads was placed behind the screen in a centrifuge and spun. The dust which left the sample was caught on a plug, and the increase in weight of the plug indicated the amount of dust removed at a certain acceleration. We plotted this mass-loss *vs* centrifuge speed for our results.

A companion experiment was one which determined the charge on the dust in the sample. In this experiment the charge on the dust was determined by blowing the dust from the beads while the beads were restrained inside a screened metal cage⁸. The charge left behind as the dust left the cage was measured by an electrometer and the mass of dust removed was measured by the weight loss of the cage. In the experiment, increments of dust were blown from the cage and the charge density of the increments was computed. Thus, we could plot the incremental charge density as a function of dust concentration of the beads.

Our bead-powder mixture experiment involved an unconventional sample in the sense that surfaces are aligned at random to the force. It therefore seemed useful to measure the angular dependence of the attachment of the dust to a curved surface. This became particularly important in the light of the work by St. John and Montgomery⁵. In our more conventional experiment we applied dust via cascades or via an aerosol to the outside surface of a centrifuge tube and put the tube in an oversize hole in the centrifuge rotor. As the tube spun—supported on the inside by a mandrel—only the outside edge of the 28 mm tube touched the rotor wall. Accelerations to 15,000 g were achieved on the dust, but since the tube was large the acceleration varied from point to point over the tube's surface. On the front side of the tube the powder was experiencing both normal and shear tension. At the 90° points the dust experienced pure shear and at random angles on the back side of the tube the powder was being sheared and compressed into the surface of the tube at the same time. Figure 3 is a picture of one of these dusty tubes.

We measured the amount of dust removed from the tube with the apparatus sketched in Figure 4. A transmission densitometer was mounted so that the light source was inside the tube and the photomultiplier was outside. Thus,

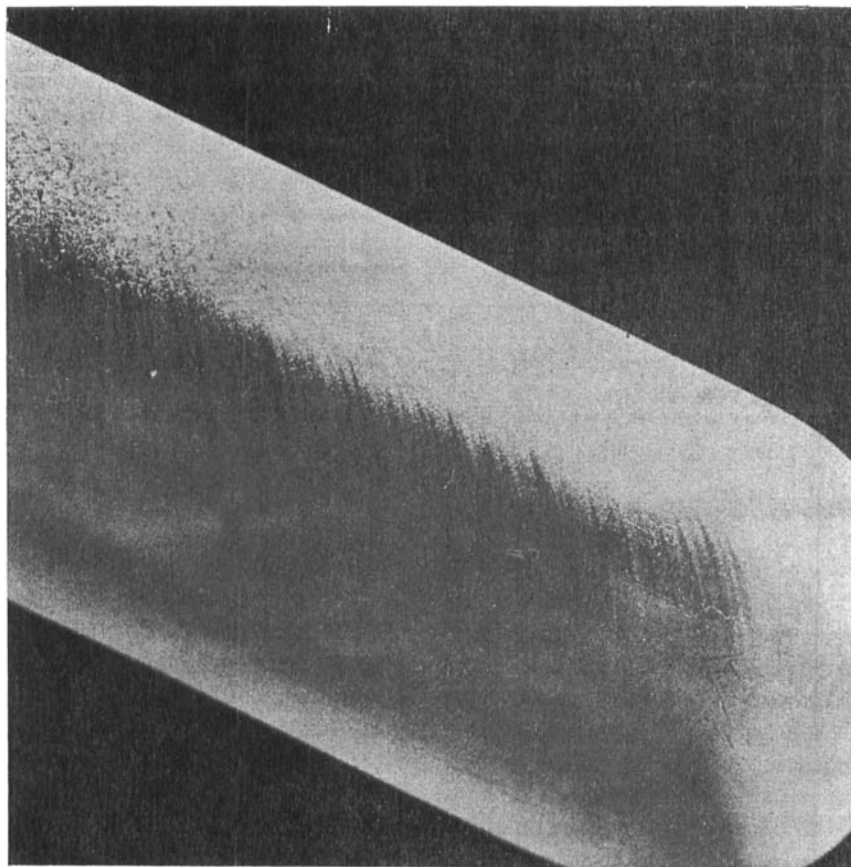

FIGURE 3 A section of the spun centrifuge tube showing avalanche tracks formed as the particles slid from top to bottom.

as the sample was slowly turned a plot of light transmitted through the dust layer was plotted by a chart recorder. The width of the light beam examined by the densitometer was about 1 mm resolving about 5° .

We estimated the local concentration of surface dust via the optical density. Other workers in xerography¹¹ and electrography¹² have demonstrated that opaque particles produce a linear relationship between optical density and mass of dust per unit area on a surface over a wide range of coverage.

The charge density of the dust was measured on the curved surface experiment as well as on the bead-powder experiment. We measured the charge density of the dust by blowing the dust from the surface of the tube and measuring the charge and mass of the tube by means of an electrometer and pan balance.

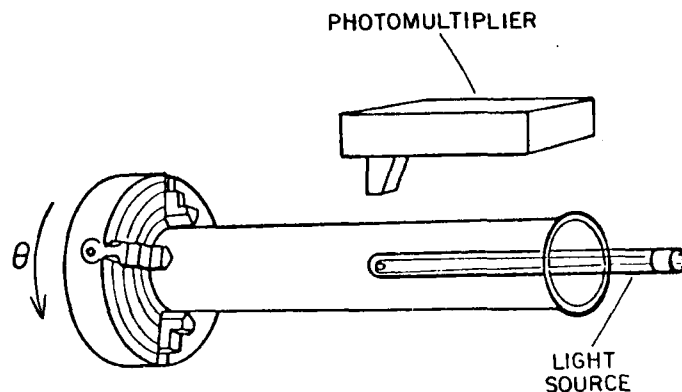

FIGURE 4 A centrifuge tube mounted in the densitometer for the measurement of Fig. 7.

RESULTS

We found that the charge of the dust on the beads could be directly related to the attachment force of the dust on the beads². For example, we consider a fixed fraction of the dust removed from the beads in Figure 5, in which we plot the amount of force required to remove 6% of the available dust against the average charge density associated with removing all of the dust from the beads. Later the experiment was refined: in Figure 6 the incremental charge density is plotted against the concentration of dust on the beads. On the right-hand ordinate is plotted the incremental speed of the centrifuge as a function of the concentration of the dust on the beads. Figure 6 actually includes the experimental results for three entirely different powders on beads. We found that the charge density of the dust exceeded $30 \mu\text{c/g}$ ($Q = 30 \times 10^{-15}$ Coul, i.e. 2×10^5 electronic charges/particle) in several experiments.

Angle played an important role in the attachment of our dust to the centrifuge tube surface. In Figure 7 we plot the initial, nearly uniform, transmission *vs* angle and the subsequent transmission *vs* angle after spinning at 12,000 g. As the acceleration increased more of the dust was spun off the higher angles just as St. John and Montgomery have reported⁵. As mentioned before, an angle of 180° corresponds to dust being pressed directly into the centrifuge tube. An angle of 0° corresponds to pure tension forces acting on the dust particles as can be seen from Figure 7(a). Dust has fallen off the "roof" of the tube—but not at the peak—a surprising result which has already been reported. A small difference in removal between leading and trailing edges of the tube is ignored. Within our accuracy the angular dependence of detachment was the same for lead chromate, zinc and graphite, among other dusts.

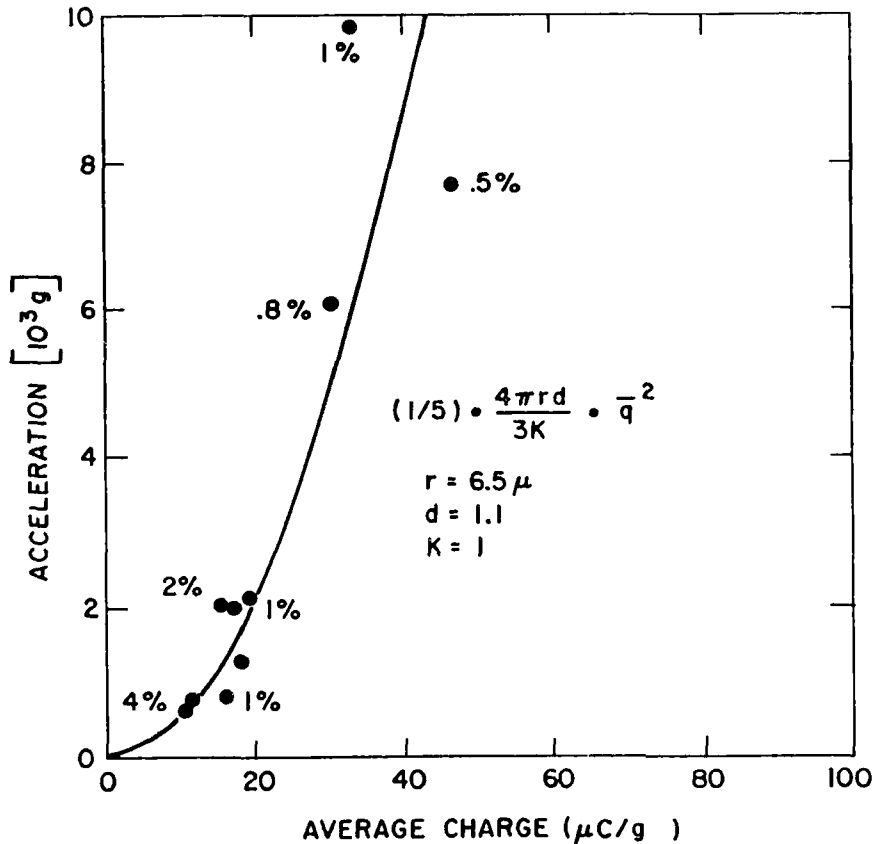

FIGURE 5 Attachment vs average charge for a family of dust mixtures at different concentrations².

The telltale tracks of dust avalanches are visible as inhomogenities in the dust residue as the particles fell from top to bottom in Figure 3.

The charge per particle of the dusts on the centrifuge tube were comparable to the charge density experienced in the bead-powder experiments. Gold particles showed very low surface coverages—only a tiny fraction of the available dust stuck. The dust which did stick was charged. For example, roughly 15 micron radius gold dust¹³ charged to an average $Q \sim 22 \times 10^{-15}$ Coul/particle and require about 400 g in tension to begin falling off of the cylindrical sample. Macroscopically this powder was an insulator if less than 30 volts was applied between two electrodes, provided no external pressure was applied to compact the powder. With an external pressure of the order of 1 psi the powder became conducting as the tarnish layers were ruptured.

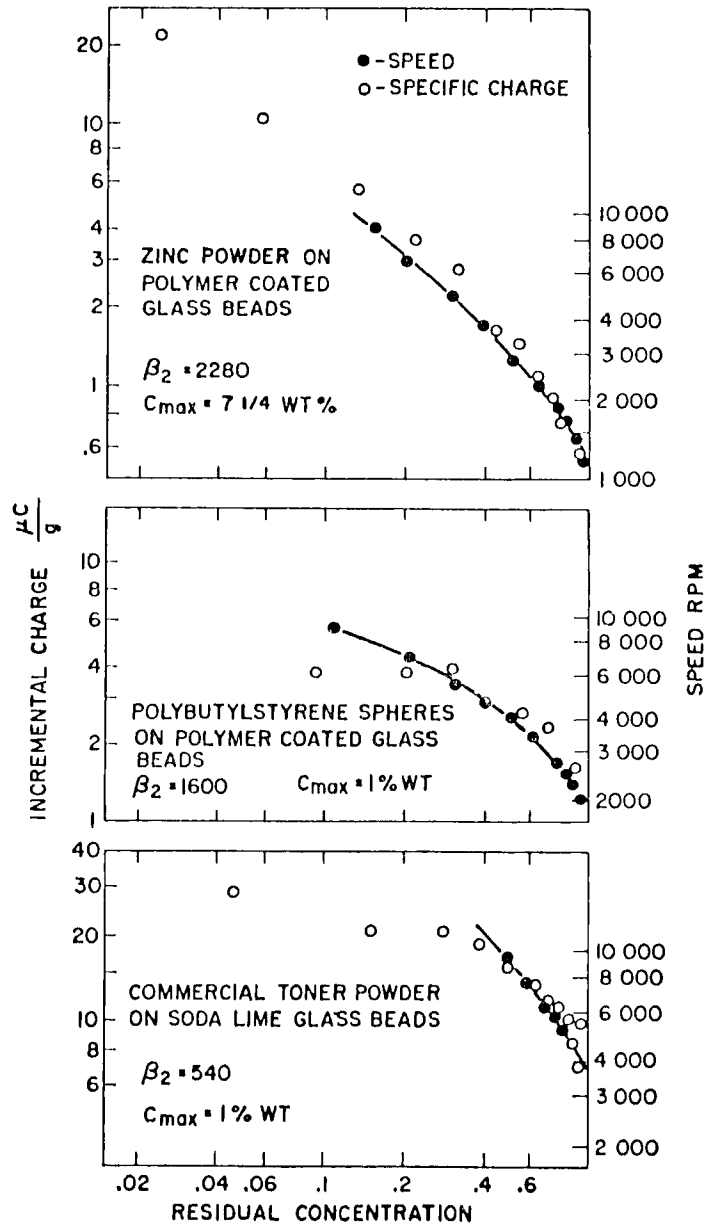

FIGURE 6 Incremental charge and centrifuge speed both plotted vs dust concentration².

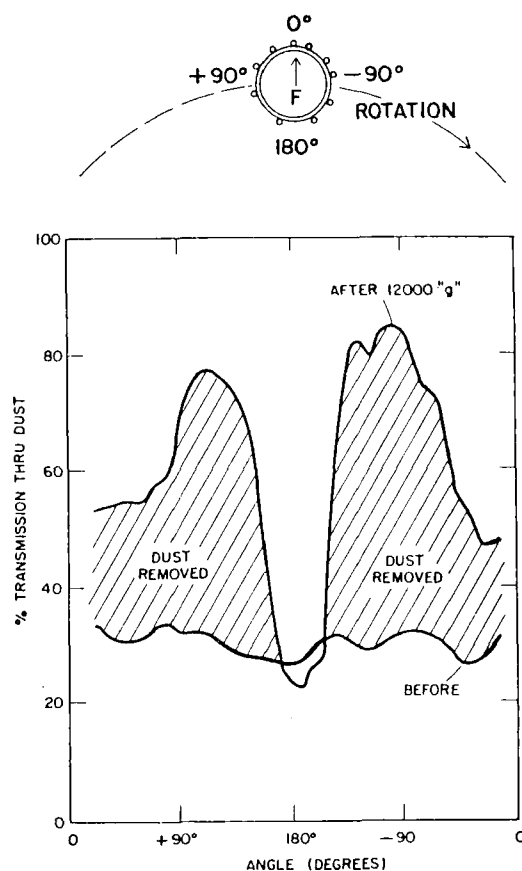

FIGURE 7 The light transmitted through the tube as a function of angle. A cross section of the tube is included.

DISCUSSION

We have demonstrated the utility of examining the electrostatic properties of dusts in connection with dust attachment to surfaces. The experiments demonstrate that the charge and the attachment force are strongly related to each other. This occurs on both small bead surfaces as well as large gently curving surfaces. Our experiments were all performed at high coverages compared with those used by other workers. Regardless of coverage the results provide a useful tool for examining the properties of adhesion of dusts.

We have treated adhesion measurements of metal particles as if the metal particles were electrically isolated from the substrate on which they were

tested. We have done this in spite of the fact that many of the experiments in the literature use noble metals such as gold and silver particles for testing adhesion theories. Our justification for using this isolated-particle approach is the pervasiveness of tarnish layers. Holm¹⁴ in his treatise of electrical contacts has examined the nature of tarnish in considerable detail and the impact of this tarnish on the electrical properties of relay contacts. Subsequently Maddock *et al.*¹⁵ examined the properties of gold relay contacts at milligram closure forces. Maddock's experiments complemented the ones reported by Holm and extended the data to lower forces where the tarnish on gold becomes very important.

If we substitute numbers into Eq. 2 we can achieve an experimentally observed force. For example we have 15 micron radius particles which have an average charge on them of about 22×10^{-5} Coul. We observed earlier² that the particles with high charge have about three times the mean charge. Let us choose $Q = 66 \times 10^{-15}$ Coul and then establish what α is necessary to achieve the force of 0.5 dyne reported by St. John. In this case $\alpha = 100$ is necessary and equation 3 implies the particles would be covered with about 70 Å of tarnish. If the observed force were 0.25 dyne then the inferred oxide thickness is 180 Å. Such a tarnish layer could be insulating just as we observed.

In Figure 2 we have a prediction of the adhesion force as a function of the particle radius on the basis of electrostatic adhesion. Since St. John and Montgomery have measured the attachment force *vs* radius, we can compare our adhesion model of Eq. 2 to the experiment. Figure 8 is a copy of St. John and Montgomery's observations and it is clear an "n" in the analysis can be chosen to fit the experimental force-versus-radius dependence.

All of the discussion here describes arguments which apply in tension. Something must prevent the particles from rolling when particles experience both tension and shear. St. John and Montgomery's description or Zimon and Serebryakov's¹⁶ model seem to be all we have to deal with spherical sheared particles. Electrostatics can occur here too, however. Particles in compression and shear sitting on asperities would have their tarnished films in compression; if charge leaks through the highly compressed section of tarnish then the particle could lose its charge in a short time, lose its attachment force, and then fall off the surface.

Since we have seen evidence of dust avalanches in these experiments we conclude dust knock-on effects are potentially important and thus the dust reported in our earlier work² had in it an admixture of knock-on effects which complicates detailed interpretation. We believe future adhesion experiments will show that electrostatics are most pervasive in adhesion experiments.

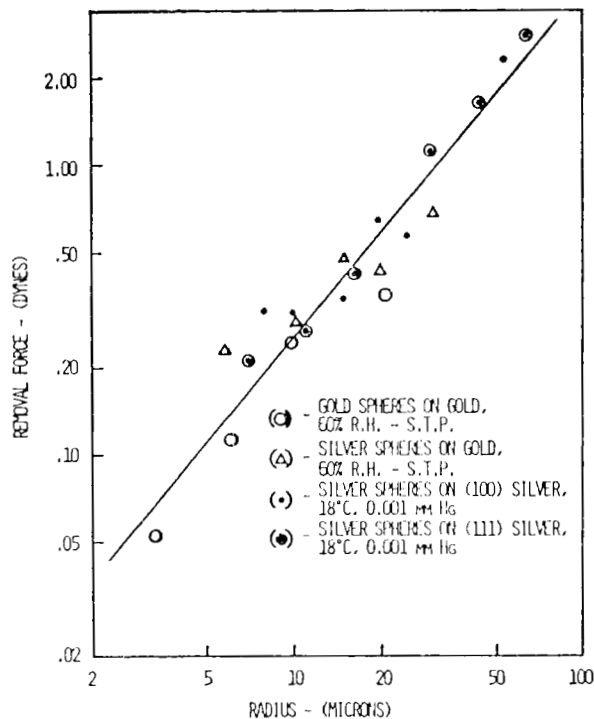
FIGURE 8 Tensile rupture force vs radius⁵.

Acknowledgements

It is a pleasure to acknowledge the encouragement and suggestions of P. K. Watson, the experimental assistance of J. C. Maher and the helpful comments of J. E. Cranch.

References

1. M. C. Kordecki & C. Orr Jr., *Arch. Environ. Health* **1**, 1 (1960).
2. D. K. Donald, *J. Appl. Phys.* **40**, 3013 (1969).
3. D. K. Donald & P. K. Watson, *Phot. Sci. & Eng.* **14**, 36 (1970).
4. W. Kottler, H. Krupp and H. Rabenhorst, *Z. Angew. Phys.* **24**, 219 (1968).
5. D. F. St. John & D. J. Montgomery, *J. Appl. Phys.* **42**, 663 (1971).
6. M. H. Davis, *Am. Jour. Phys.* **37**, 26 (1969).
7. W. Kottler, H. Krupp & H. Rabenhorst, *Rev. Sci. Inst.* **38**, 589 (1967).
8. J. H. Dessauer and H. E. Clark, *Xerography and Related Processes* (Focal Press, 1965), p. 289.
9. B. V. Derjaguin & V. P. Smilga, *J. Appl. Phys.* **38**, 4609 (1967).
10. W. Schnabel, *Advances in Static Electricity* **1**, 33 (Vienna 1970).
11. J. T. Bickmore *et al.*, *Phot. Sci. & Eng.* **14**, 42 (1970).
12. J. A. Dahlquist and I. Brodie, *J. Appl. Phys.* **40**, 3020 (1969).
13. Metz Refining Company, South Plainfield, N.J.
14. R. Holm, *Electrical Contacts Handbook* (Springer, 1958).
15. A. J. Maddock *et al.*, *Brit. J. Appl. Phys.* **8**, 471 (1957).
16. A. D. Zimon & G. A. Serebryakov, *Russ. J. Phys. Chem.* **45**, 249 (1971).